

## Industrial Vacuum Cleaner

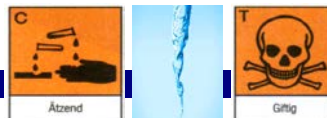

Electrically Operated

### Vacuum cleaner for acid / chloride

#### Industrial vacuum cleaner with integrated preseparator for high concentration of acids and corrosive liquids

Vacuum cleaner for acid VASN PE >>>Polyethylen<<<

Vacuum cleaner for acid VASN PVDF >>>Polyvinylidenfluorid<<<

#### Application

Vacuum cleaners are made of acid-resistant material and can be used for the recovery of acid, corrosive liquids and the medium is hazardous to health. The cleaners contains a 5kg activated carbon cartridge made of electrically conductive Polyethylene for the adsorption of gas, vapors, fumes and odors from acid and chloride.

Special accessories of electrically conductive Polyethylene ensure maximum safety in handling acids.

Due to the short preparation time and easy handling are the units quick serviceable.

The units are designed with a detachable recovery tank on wheels with a capacity 60 liters.

#### Safe disposal of problematic liquids

Pumping off is the only solution to the safe disposal of dangerous or non dangerous fluids. KRAHNEN supplies a diaphragm pump integrated in the cleaner. In this way, the fluid can be disposed of safely in a "closed loop" system without interruption the cleaning process.

#### Features / Advantages

- Can be used to recover acid
- Reliable and built-to-last side channel blower
- Available in different power levels
- Mobile units
- Highest safety and technical quality
- All stainless steel construction incl. cart
- Reduced noise level
- Robust yet light weight

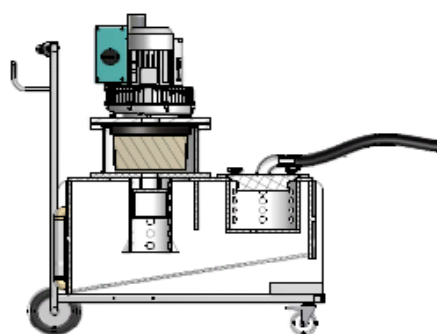
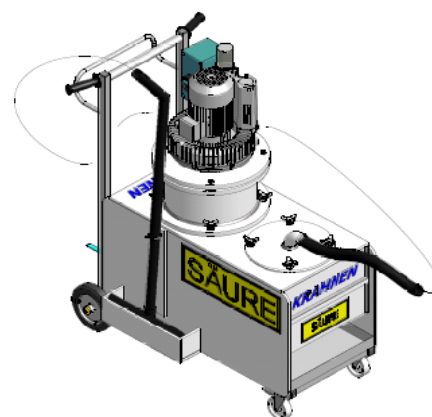

Activated Carbon Filter



Safety connection

Accessories	
Type	Part number
Diaphragm pump	see accessories catalogue
Suction hose	see accessories catalogue
Nozzles	see accessories catalogue
Separator	see accessories catalogue

#### Also available:

- to use in EX-Zone!
- with a 230V motor!
- only as a Separator!
- completely made in Polyethylene!
- air driven!

Technical features		Type	Liter	Filter	Medium	Part no.
Engine	Side channel blower	VASN AK PE	60	AK	acid	on demand
Power	1,1 / 1,85 / 3,3 kW	VASN AK PVDF	60	AK	acid	on demand
Normal Voltage	400 V / 50 Hz. [IP 55]					
Suction volume max.	145 / 270 / 320 m³/h					
Vacuum max.	170 / 200 / 270 mbar					
Capacity	60 liter					
Filter area	~ 5.000 cm²					
Hose entry	38/50 mm					
Weight	62 kg					
Noise level	72 dB (A)					
Dimensions LxWxH						
		Supplied with:				Part no.
		Activated-charcoal filter				2005020