

Mobile deduster DUSTOMAT P

Range of application

The mobile-DUSTOMAT dust have proved in recent years in many commercial and industrial enterprises. They suck dust and chips, resulting from production processes, from safe and provide for clean and healthy workplaces. The new DUSTOMAT T-and P-series delivers air through their technical optimization, and even more compact design. For the uniform flow of the filter elements in filter housing provides a built-in type collectors. Also guarantees the separation of coarse particles, long filter life. Depending on the application environment, the devices can now be optionally equipped with one of two Filter types: Filter cartridge and bag Filter are located in different versions before dedusting.



Properties/Advantages

- Low operating costs
- Slight dust disposal
- Standalone or central suction used as mobile
- Optional with Mark for special applications
- Single and multiple workstations in industry and crafts
- Free-flowing dusts
- Dry chips
- Depending on model, there are 2 Abreinigungsvarianten available:
Jet-cleaning bag and motor filter cleaning
- Integrated type collectors
- Depending on model: cleanable filter cartridge for dust class M
- Nachfilterkassette (dust class H) as an option
- Test certificates H, H3, GS
- Optionally available as ATEX version

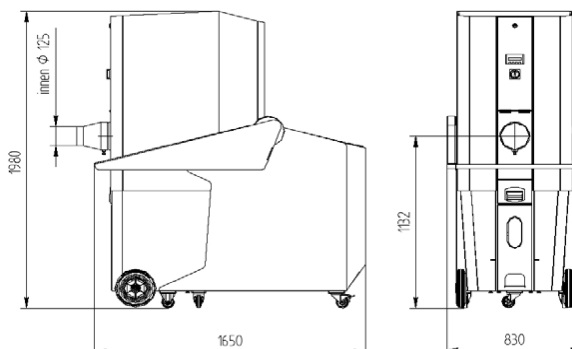

Technische Daten		Modell	Cont./L	Dust class	Art.Nr.
Engine	Side channel blowers	DUSTOMAT T-5 M	200	M	
Power	2,2 kW / 3,0 kW	DUSTOMAT T-5 MH	200	M/H	
Power consumption	400 V - 50 Hz.	DUSTOMAT T-5 ATEX	200	M	
Intake volume	1.500 / 2.500 m³/h, max.	DUSTOMAT T-5 H ATEX	200	M/H	
Vacuum	2.300 (PA), max.	DUSTOMAT T-10 M	200	M	
Container volume	200 l	DUSTOMAT T-10 MH	200	M/H	
Filter material	Dust class M	DUSTOMAT T-10 ATEX	200	M	
Filter cleaning	motor	DUSTOMAT T-10 H ATEX	200	M/H	
Compressed air requirement	28,8 (l/min)				
Compressed air connection	1/4"	Accessories			
Total filter area	5.000 / 10.000 cm²	Description			Art.Nr.
Hose connection	125 / 180 mm	suction arm			siehe Zubehörkatalog
Empty weight	320 kg	vacuum cleaner			siehe Zubehörkatalog
Noise level	72 dB (A)	bag			siehe Zubehörkatalog
Dimensions LxWxH	1650x830x1980 mm/ 200l				